



Print & Apply Labeller with Intelligent Motion™

# Videojet® 9560 Front of Pack

The Videojet 9560 Front of Pack is a smarter print and apply labeller that is designed to target zero unscheduled downtime and can help reduce costs and errors in case coding operations.

Videojet Intelligent Motion™ technology automatically and precisely controls the entire system, helping to remove operational downtime often caused by label jams and snagged labels. A robust and simply designed applicator makes it easy to use, plus an integrated pack detect feature helps ensure accurate label placement.

The 9560 with Front of Pack applicator is ideal for cases or shrink wrapped products where the label must be applied on the leading panel of the pack.

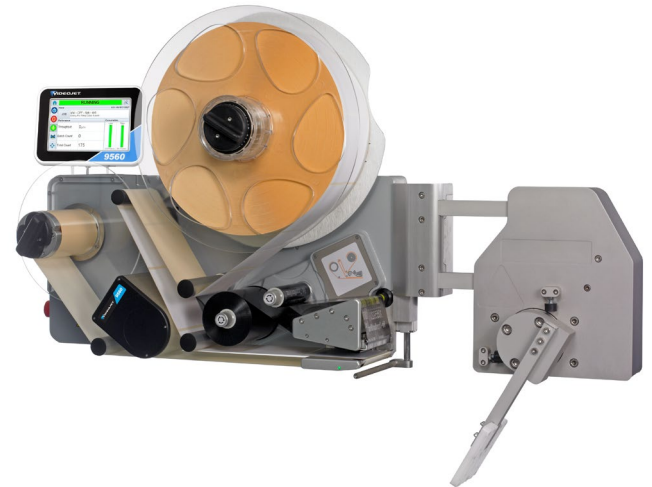

## Industry-proven labelling technology

- Optimise maintenance labour by removing common wear and adjustment parts
- Built-in pack/case detect sensor eliminates the need for additional components, simplifying integration and set-up
- Clean, robust design helps protect components during operation
- Eliminate label jams for common top or side labelling applications

## Remove end-of-line inefficiencies

- Intelligent Motion™ technology delivers automatic control of the system and eliminates the added parts and adjustments that can make other labelling machines fail
- A direct drive controls label speed and position without clutches, rollers or adjustments
- Electronic supply reel automatically adjusts and maintains tension irrespective of speed and label size

## Seamless connectivity and compatibility

- Virtually eliminate operator errors, helping to ensure products are coded correctly with built-in Code Assurance software features
- Includes embedded Wi-Fi for secure remote access and analytical capabilities
- Intelligent emulation capabilities include EtherNet/IP™, PROFINET®, Zebra, SATO and CoLOS protocols

## Simple usability

- Perform label and ribbon changes in less than 60 seconds
- Single simple 8-inch user interface for easy control
- Onboard support videos guide the operator through routine tasks
- Flexibility to position user interface remotely
- Ability to access the interface on a connected network, including via mobile devices

# Videojet® 9560 Front of Pack

Print & Apply Labeller with Intelligent Motion™

## Application method

Top mount swing arm with 12.0" (305mm) reach

## Print technology

Thermal Transfer printing with Intelligent Motion™ Ribbon Drive and Direct Thermal 53mm, 76mm and 107mm printhead versions

## Print resolution

300dpi / 200dpi emulation mode

## Printhead health monitoring

Tool-free quick release printhead replacement

## Print speed

1.6 - 19.7inches/sec (40 - 500mm/sec)

## Throughput

Up to 60 packs per minute (depending on label size, telescopic stroke)  
Recommended max. conveyor speed 98.4ft/min (30m/min)

## Ribbon specification

Width: 2.2" (55mm), 3.0" (76mm) and 4.3" (110mm) standard  
Capacity: Up to 830m, including automatic ribbon save (<1mm ribbon gap between successive prints irrespective of label size or speed)  
Low Ribbon and End of Ribbon detection with predicted changeover time built in as standard

## Label specification

Label Width 2.0" to 4.5" (50mm to 115mm); dependent on printhead version  
Label Length 2.0" to 5.9" (50mm to 150mm)  
Capacity: Up to 400mm spool diameter (typically delivers over 9000 typical GS1 bar code labels per roll)  
Low Labels and End of Label Reel detection, with predicted changeover time built in as standard  
Automatic adjustment for label/backing type and label size

## Tamp sizes

Standard: 100mm x 100mm  
Optional: 50mm x 120mm, 75mm x 120mm, 100mm x 50mm, 100mm x 70mm, 100mm x 150mm

## Print capabilities

Full downloadable font support using TrueType® fonts (including multiple languages and Unicode support); fixed, variable and merged text fields; flexible date/time formats; flexible shift code formats; auto best before date calculations and concession management; calendar rules; auto incrementing/decrementing text, counters and bar codes; multiple graphic formats supported (up to maximum print area); link fields to databases; scalable text and text blocks; 1GB on-board label database, sufficient for 625,000 typical GS1 bar code label designs

## Bar codes supported

EAN 8, EAN 13, UPC-A, UPC-E, Code 39, GS1-128, Code 128, ITF, RSS (including 2D composite codes); others available upon request

## Connectivity

Ethernet, Power-over-Ethernet, RS232, Configurable I/O (24V, PNP and volt-free) USB (for backup/restore and label upload), remote Control Videojet 9560 via a web browser

## Communications Protocols

Compatible with Videojet Clarisuite™ software  
Videojet binary and simple-ASCII protocols  
Compatible with any label design software which supports Zebra or Sato print engines  
Zebra (ZPL), Sato (SBPL) and Markem-Image (Cimcomms) protocol support  
EtherNet/IP™  
PROFINET®

## Interface

CLARiTY™ Controller with Interactive on-board video tutorials

## Language Capabilities

Arabic, Bulgarian, Czech, Danish, English, German, Greek, Finnish, French, Hebrew, Hungarian, Italian, Japanese, Korean, Dutch, Norwegian, Polish, Portuguese, Romanian, Russian, Serbian, simplified Chinese, Slovak, Spanish, Swedish, Thai, Turkish, Traditional Chinese, Vietnamese

## Compressed Air

6 Bar. 90psi, uncontaminated

## Power Consumption

90-260 VAC (115W at 50 packs per minute)

## Operating Environment

Temperature Range: 41-104°F (5-40°C)  
Humidity: 20-85% Relative, non-condensing

## Weight

Front of Pack applicator - 24.25lbs (11kg)  
9560 excluding ribbon and labels - max. 88.19lbs (40 kg)

## Applicable certifications

CE, TÜV

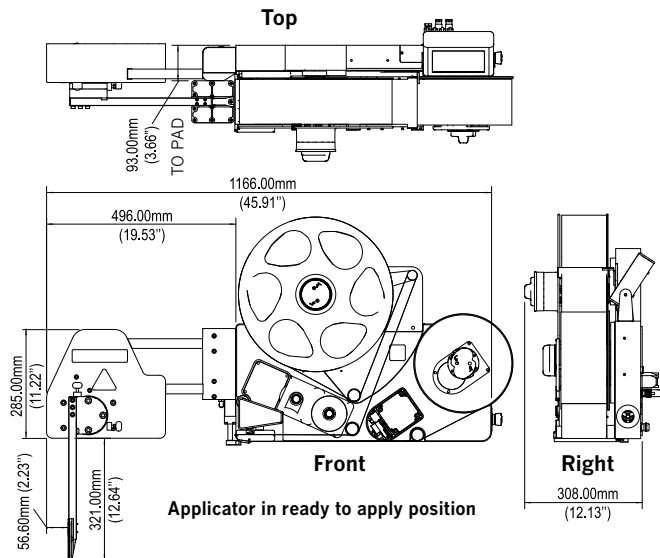

Call us free on **0800 500 3023**  
Email [uksales@videojet.com](mailto:uksales@videojet.com)  
or visit [www.videojet.co.uk](http://www.videojet.co.uk)

Videojet Technologies Ltd.  
4 & 5 Ermine Centre, Huntingdon, Cambridgeshire PE29 6XX / UK

Call us free on **+353 1 450 2833**  
Email [irelandsales@videojet.com](mailto:irelandsales@videojet.com)  
or visit [www.videojet.ie](http://www.videojet.ie)

Videojet Ireland  
C2, South City Business Park, Tallaght, Dublin 24 / Ireland

© 2024 Videojet Technologies Inc. — All rights reserved.

Videojet Technologies Inc.'s policy is one of continued product improvement. We reserve the right to alter design and/or specifications without notice. TrueType is a registered trademark of Apple Computer, Inc.

Part No. SL000733  
ss-9560-front-of-pack-en-0724

